

Global. Connected. Sustainable.

INVESTOR PRESENTATION

SEPTEMBER 2025

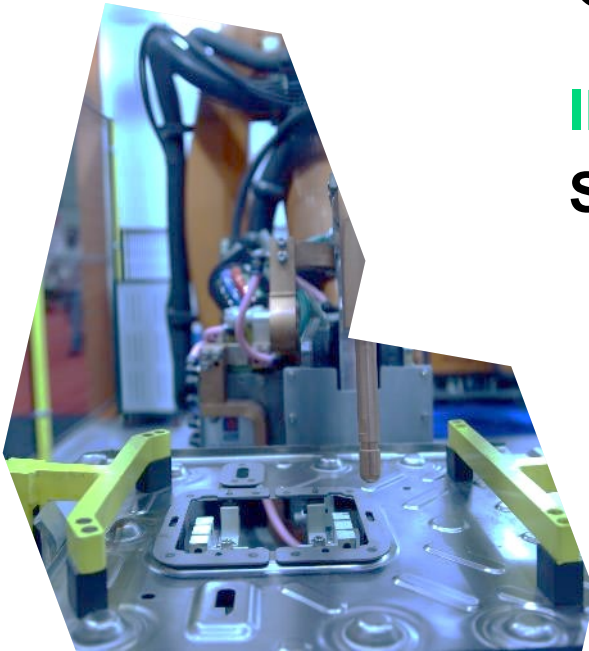

**The meeting place
for companies,
technologies and data**



Digital Realty Overview



A Global Data Center and Connectivity Platform Supporting our Customers' Critical IT Architecture

5,000+ Customers ⁽¹⁾
 229,000+ Cross Connects ⁽¹⁾
 50+ Metros ⁽¹⁾
 300+ Data Centers ⁽¹⁾

EQUITY & ENTERPRISE VALUE

\$60 Bn

EQUITY MARKET CAPITALIZATION ⁽²⁾

\$80 Bn

ENTERPRISE VALUE ⁽³⁾

TOP PUBLICLY TRADED U.S. REIT

4th

LARGEST PUBLICLY TRADED U.S. REIT ⁽⁴⁾

2016

ADDED TO THE S&P 500 INDEX

INVESTMENT GRADE RATINGS ⁽⁵⁾

FitchRatings
BBB

MOODY'S
Baa2

S&P Global
BBB+



Note: Balance sheet data as of June 30, 2025 unless otherwise indicated.

1) Totals includes buildings held as investments in unconsolidated joint ventures.

2) As of June 30, 2025.

3) Total enterprise value calculated as the market value of common equity as of June 30, 2025, plus liquidation value of preferred equity and total debt at balance sheet carrying value as of June 30, 2025.

4) U.S. REITs within the RMZ. Ranked by market cap as of June 30, 2025. Source: Bloomberg.

5) These credit ratings may not reflect the potential impact of risks relating to the structure or trading of the Company's securities and are provided solely for informational purposes. Credit ratings are not recommendations to buy, sell or hold any security, and may be revised or withdrawn at any time by the issuing organization in its sole discretion. The Company does not undertake any obligation to maintain the ratings or to advise of any change in ratings. Each agency's rating should be evaluated independently of any other agency's rating. An explanation of the significance of the ratings may be obtained from each of the rating agencies.

Global Platform Focused on Execution of Strategic Priorities

As of June 30, 2025

STRONG LEASING

\$935mm **\$813mm**
LTM Bookings LTM Renewals

STRONG CAPITAL POSITION

> \$7 Bn **5.1x⁽¹⁾**
Liquidity Net Debt to Adjusted EBITDA

1 Strengthen our Customer Value Proposition

- Executing Meeting Place strategy with sustainable connectivity rich solutions
- Providing full spectrum product offering across a global platform
- Growing Connected Data Communities

2 Innovate & Integrate for our Customers

- Building new applications on the world's largest open network platform
- ServiceFabric® available in 38 metros
- Expansion of PlatformDigital®
- Aligned organization into three regions
- Announced High Density Colo offerings in 30+ global metros

3 Diversifying and Bolstering Capital Sources

- Partnering with private capital sources to improve capital efficiency
- Elevated focus on projects with highest risk-adjusted returns
- Reduced leverage and increased liquidity through diverse forms of capital recycling

Offering a Global Data Center Platform

Capacity in World's Major Metros to Meet Growing Customer Demand

Global Capacity

~2.8 GW

Total In-Place IT Capacity

~750 MW

Under construction

Geographically Diversified ⁽¹⁾

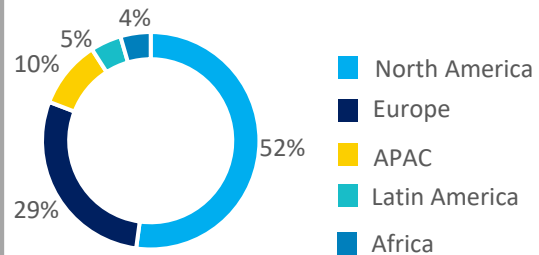

Land Bank Available to Double IT Capacity

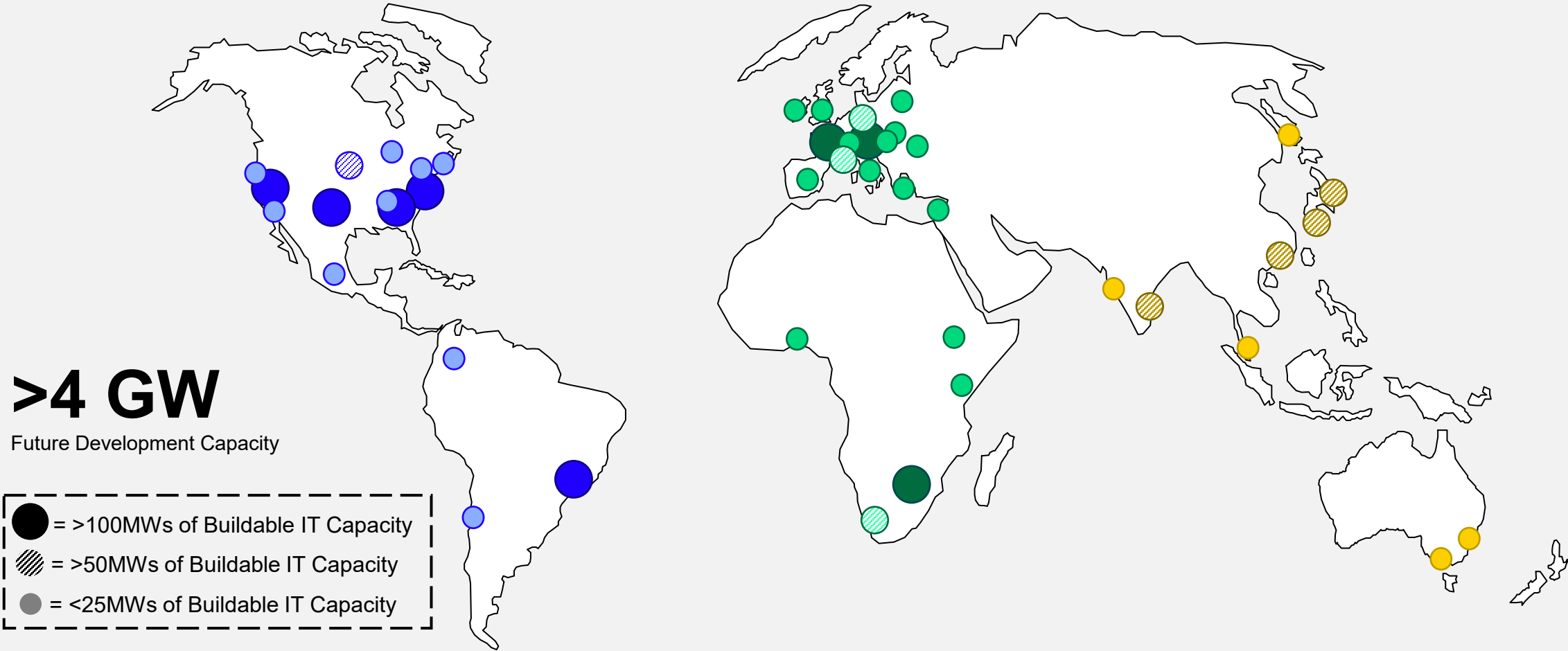

	<u>AMERICAS</u>	<u>EMEA</u>	<u>APAC</u>	<u>TOTAL</u>
Existing Capacity	1,700 MWs	800 MWs	300 MWs	2,800 MWs
Buildable Capacity	2,800 MWs	1,100 MWs	400 MWs	4,300 MWs
Total Capacity	4,500 MWs	1,900 MWs	700 MWs	7,100 MWs

Note: As of June 30, 2025. Totals reflect Consolidated and Unconsolidated facilities at 100% Share. Totals may not add due to rounding.

Digital Realty's Competitive Advantage & Execution Strategy



Customer Relationships

Long-standing, deep and **trusted partner** of many of the **largest hyperscale customers**, helping meet their exponentially growing needs

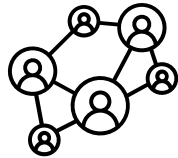

Connected Campus Approach

Connected campus approach allows for **cloud service providers, AI use cases, carriers, networks and enterprises** to all be interconnected to one another



Global Platform

Embedded internal expertise as the **world's largest data center owner, operator, acquirer and developer**

ServiceFabric®

Connectivity

Allows customers **connectivity** to cloud on-ramps, service providers and networks via DLR's proprietary network



Proprietary Expertise

Honed over the past **20+ years alongside our customers** to optimize **design, timing and costs**



Supply Chain Management

Dedicated teams to focus on **supply chain optimization** and **centralized vendor management inventory program** to optimize across all Digital Realty assets

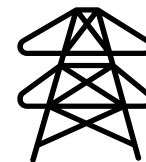

Power Procurement

Deep relationships with both **regional & local power providers** to help ensure timely power delivery



Entitlement & Local Incentives

Long-standing relationship with **local governments and city council** for tax exemption, rezoning, and other local incentives

Leading Data Center Partner for Sustainability

Building, Powering, and Operating More Sustainable Data Centers

Renewable Energy



Leading data center purchaser of renewable energy

- **1.5 GW** contracted renewable capacity
- **75%** renewable energy globally
- **185 sites matched with 100%** renewable, including Europe, New Jersey, Texas, San Francisco, and Sydney markets
- Expanded HVO diesel to **20** global sites and **17%** of our global portfolio by IT capacity

Green Buildings



More green building certified IT capacity than any other data center provider

- **1.3 GW-IT** global operating portfolio has a sustainable building certification
- **61%** of certifications are gold level and above
- **190 MW-IT** certified in 2024

Resource Efficiency



More Energy Star certifications than any other data center provider

- **ENERGY STAR Partner of the Year;** 69% of U.S. operating portfolio ENERGY STAR certified
- **Top 10** in the U.S. EPA Green Power Partnership
- **42%** of our irrigation and cooling needs came from non-potable water sources
- **Swiss Datacenter Efficiency Association (SDEA)** certification for 100% of Zurich portfolio

Green Bonds



Leading the data center industry in green bonds

- **\$7.2bn** in aggregate principal amount of green bonds issued
- **€850mm** green bond issued Sep 2024
- **Sustainability-linked credit facility** refinanced and upsized to \$4.5bn
- Executed first data center industry green bond



Strong Secular Trends

**Artificial Intelligence
Driving Next-Generation Demand**

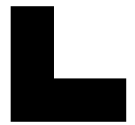

Multiple Secular Demand Drivers

Global Demand Across the Product Spectrum

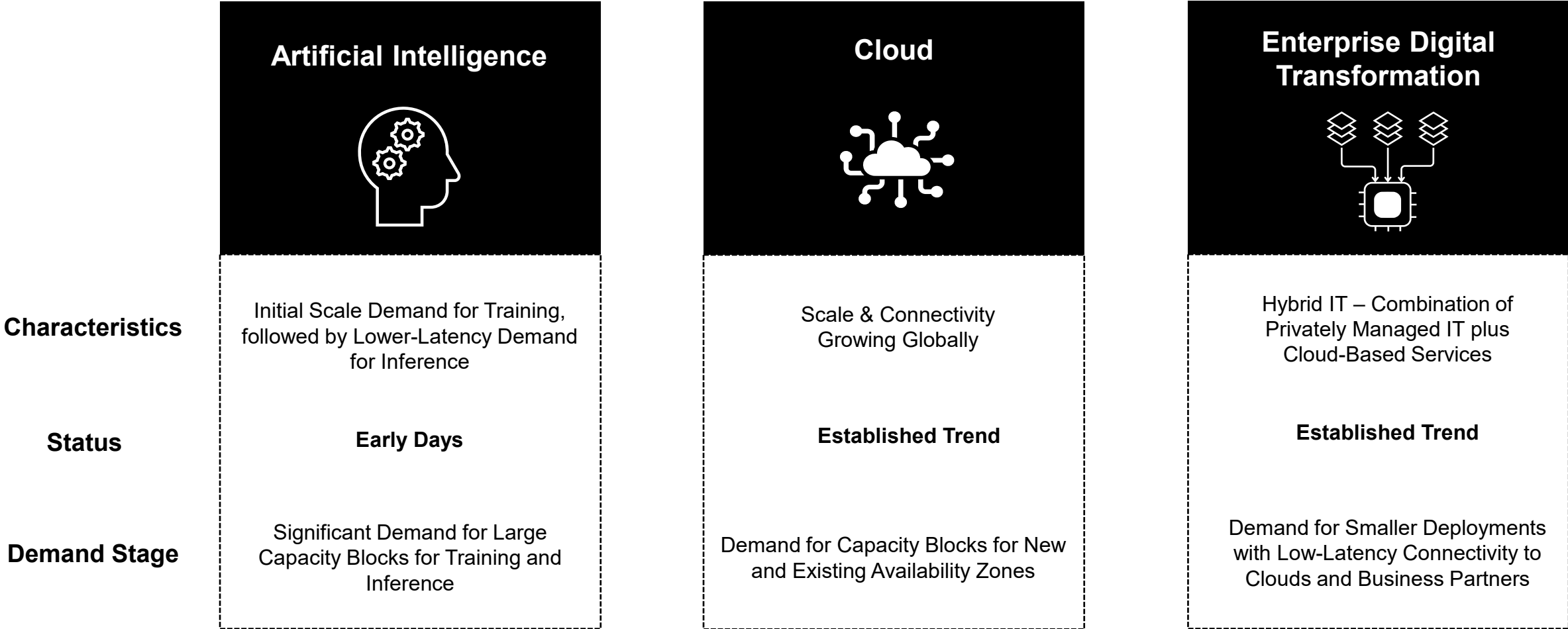

Global Data Center Demand

Cloud Transformation Fundamentals Remain Robust, While AI Has Accelerated Global Demand

BOTH AI AND NON-AI WORKLOADS ESTIMATED GLOBAL DATA CENTER CAPACITY DEMAND ⁽¹⁾

GLOBAL CAPACITY DEMAND
in GW

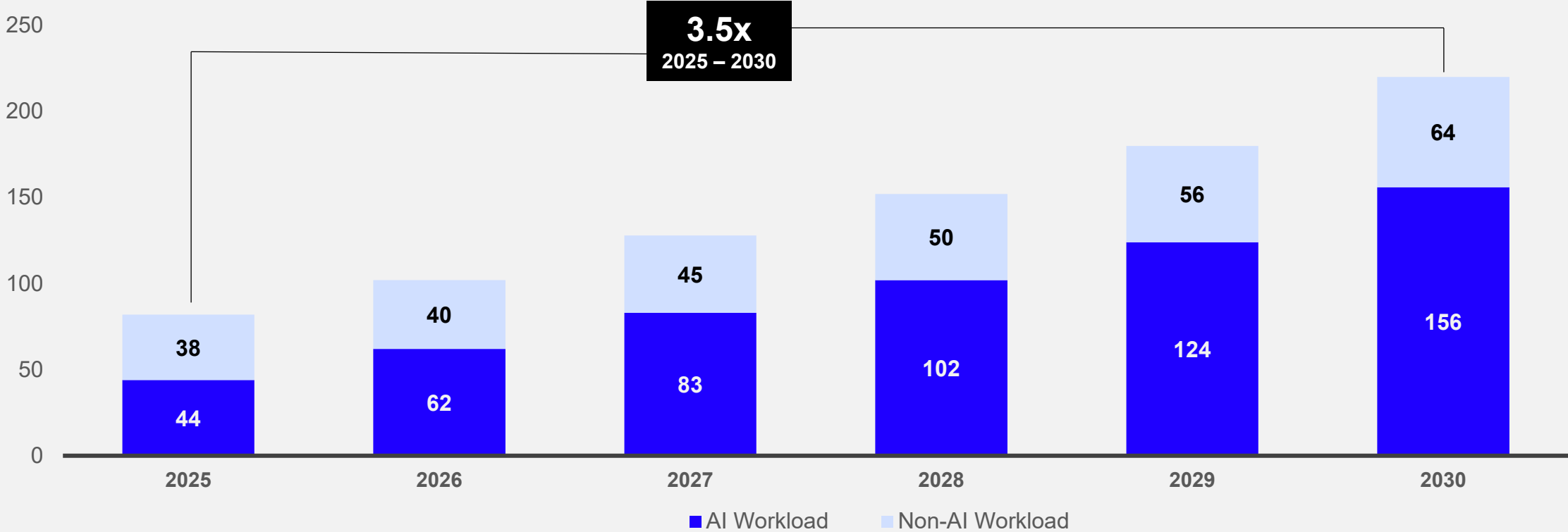

1) Source: The cost of compute: A \$7 trillion race to scale data centers (McKinsey & Company, April 28, 2025).

The PlatformDIGITAL® Competitive Advantage

PlatformDIGITAL® Seeks to Generate Greater Customer Demand, Driving Significant Returns via a Differentiated Product Offering

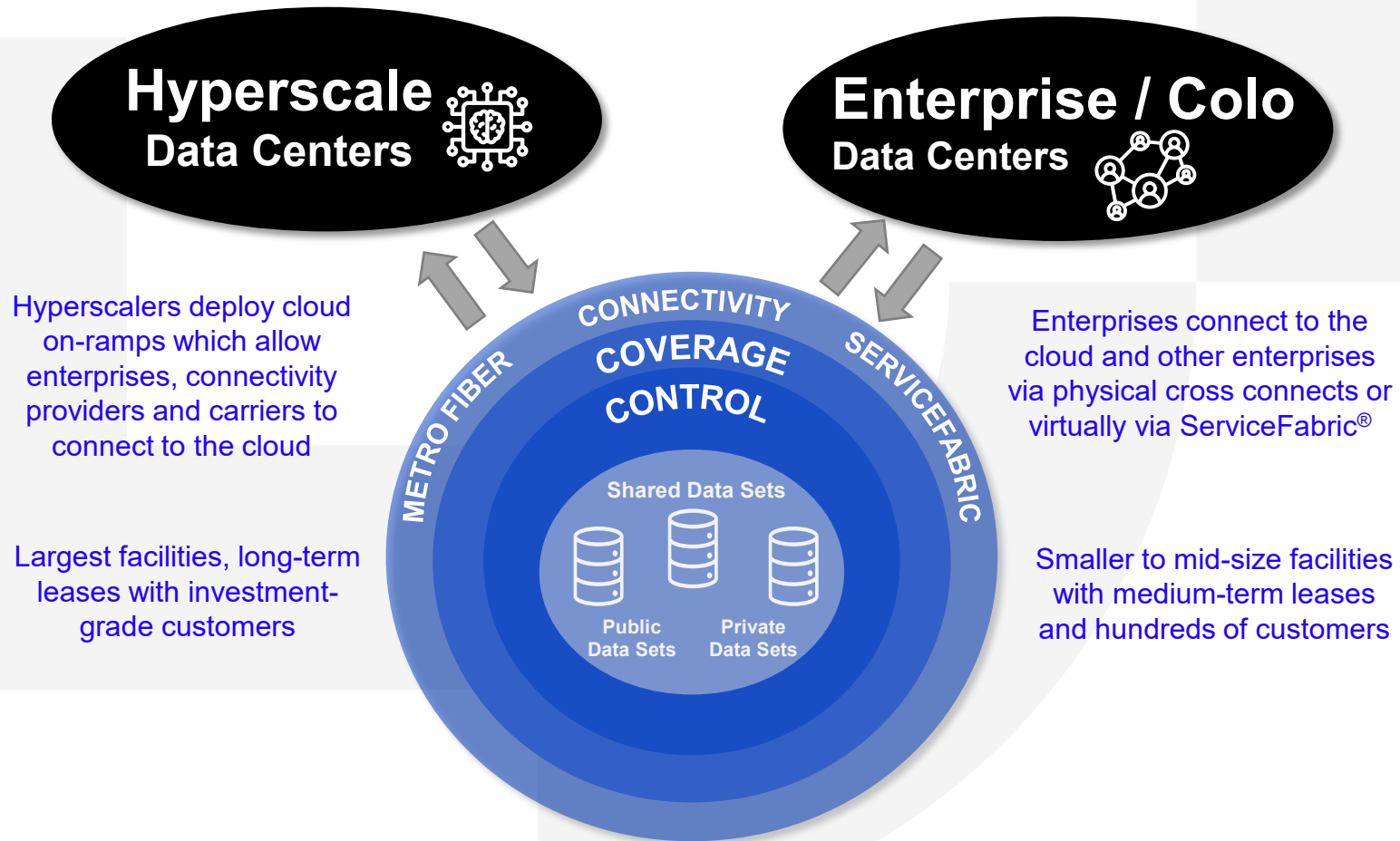

AI Platform Readiness

As power-dense workloads grow, Digital Realty's modular designs can accommodate advanced cooling solutions

Average Rack Density Increase and % of Racks above 30 kW⁽¹⁾

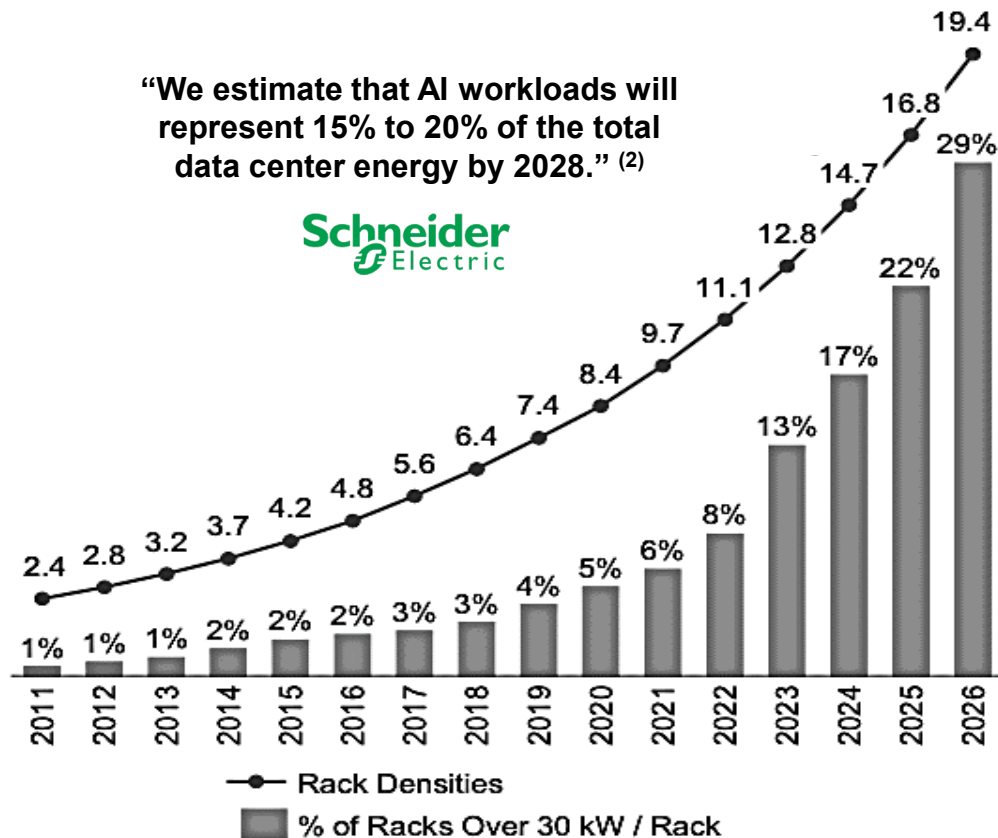

Cooling Technology by Threshold of Rack Densities

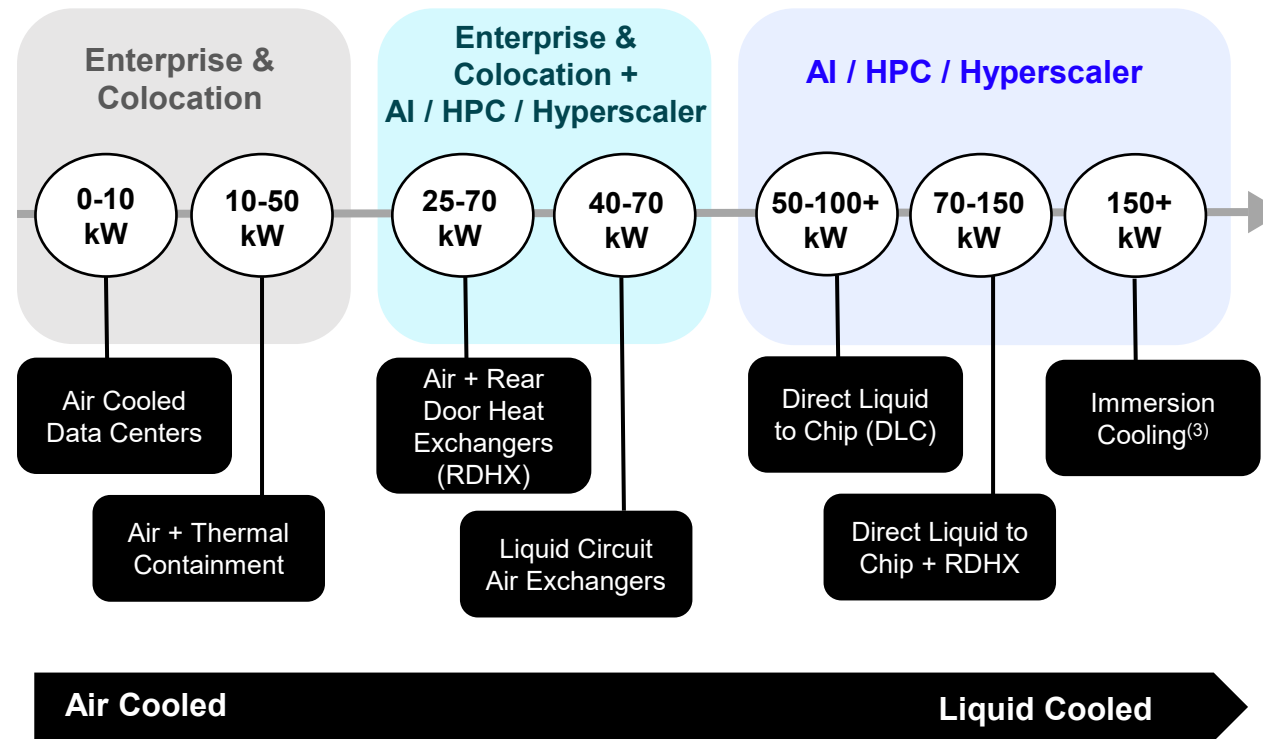

AI Continues To Accelerate and Evolve

AI Impacts How We Engage with Customers, Build our Data Centers, and Develop Our Product Offerings

1 Time to Market & Capacity are Key

2 Location Agnostic, for Now

3 Strong and Growing Demand

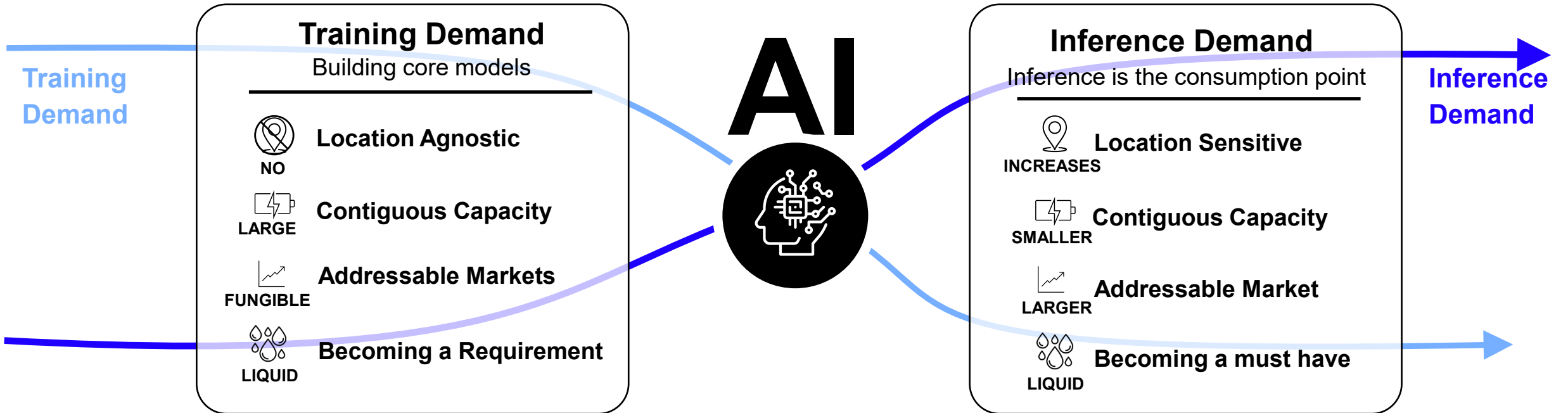

We are Carefully Navigating Our Strategy to Pursue Long-Term Value Creation Segments of AI Demand

Global Connectivity Hubs

Network Density that Promotes Innovation and Collaboration

29

METROS

Globally Where Our Internet Gateways Are Located

229K+

CROSS-CONNECTS GLOBALLY

55+

ASSETS

With Over 1,000 Cross-Connects Each

4,100+

NETWORK INSTANCES GLOBALLY



The ServiceFabric® Differentiating Factor

ServiceFabric® Seeks to Allow the Customer to Establish Numerous, Seamless Virtual Private Connections

BUILDING SERVICEFABRIC® CONNECTIONS

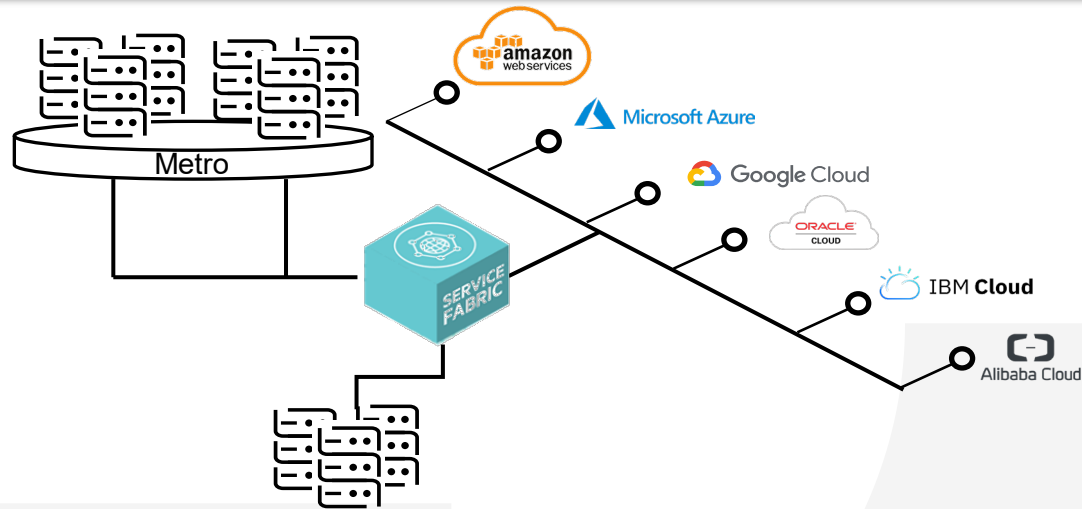

- 1 **Establish a Port**
Customers establish a port which supports multiple virtual private connections
- 2 **Connect**
Customers establish direct, private connections to multiple Cloud Service Providers, Network and SaaS Providers, and other platform participants from a single interface
- 3 **Establish Virtual Router**
Customers establish a virtual router to optimize cloud-to-cloud workflows

SERVICEFABRIC® AT A GLANCE

160+

Digital Realty Facilities
Connected Globally

500+

3rd Party Enabled
Data Centers Globally

30+

Metros Globally

300+

On Ramps Available
Globally

120+

Global Cloud Regions

100+

Digital Realty Facilities that
offer IP Bandwidth



Enterprise



Cloud Service Providers

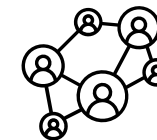

Network Service Providers



Business Partners

Private Interconnections Enable Enterprise AI Applications

Private AI Exchange (AIPx) Powered by ServiceFabric® helps enterprises alleviate data gravity barriers

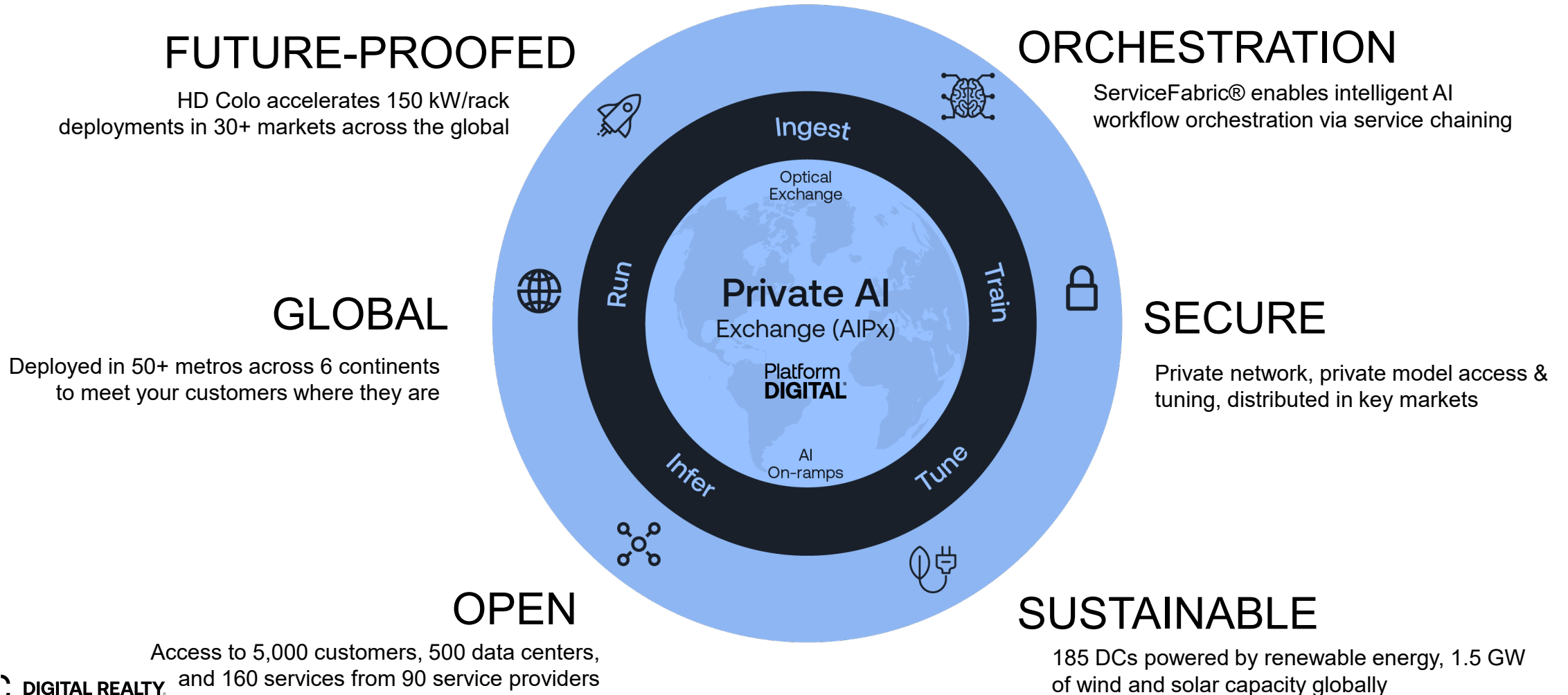



Recent Financial Results

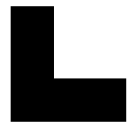

Note: Certain data in this section was originally posted to the Company's website on July 24, 2025 and has not been updated to reflect changes occurring after that date.

Executing on Key Strategic Priorities

Positioned for Long-Term Sustainable Growth

Platform
DIGITAL[®]

5,000+ Customers
229,000+ Cross Connects
50+ Metros
300+ Data Centers

Coverage

Deploy Where You Need

Capacity

Host What You Need, How You Need

Connectivity

Connect How You Need to Whom You Need

Control

Implement and Operate the Way You Need

1 Strengthen Our Customer Value Proposition

\$228Mm

Record Commencements in 2Q25

11%

Y/Y Growth in Data Center Revenue

\$1.87

Record CFFO per share⁽¹⁾

2 Innovate & Integrate for Our Customers

DLR Teams with Oracle to Enhance Deployments Globally



3 Diversify and Bolster Capital Sources

U.S. Hyperscale Data Center Fund

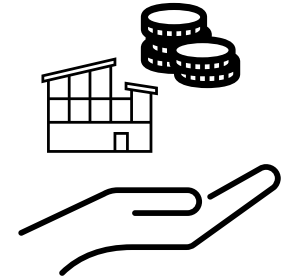

>\$3Bn

LP Equity Commitments

Strong Demand Environment

- Record 0-1MW + IX Bookings
- \$177Mm Bookings at 100% Share
- Bookings Well Distributed Across Regions

HISTORICAL BOOKINGS AT DLR SHARE

ANNUALIZED GAAP BASE RENT

\$ in millions

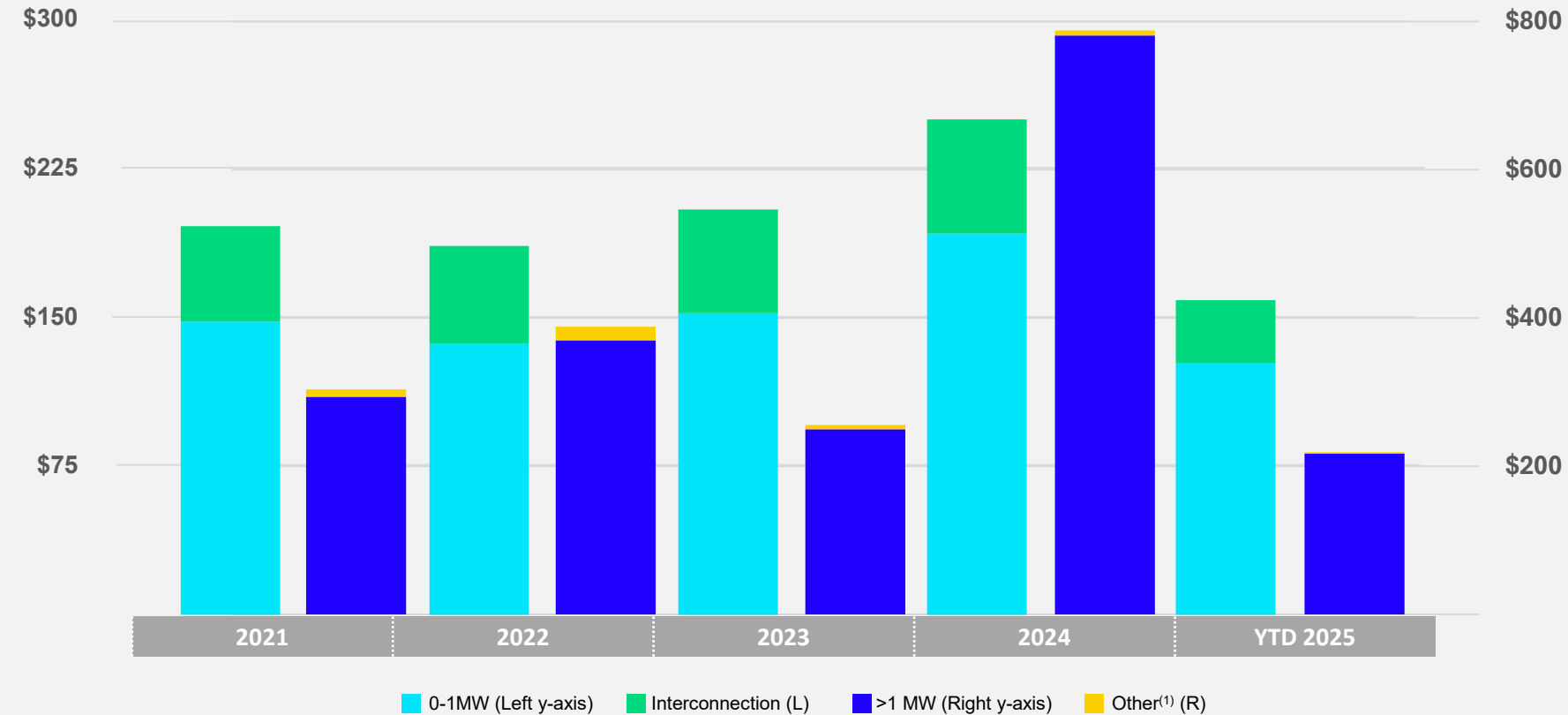

2Q25 BOOKINGS AT DLR SHARE



Note: Totals may not add up due to rounding.

1) Other includes Powered Base Building® shell capacity as well as storage and office space within fully improved data center facilities.

Enabling the Meeting Place

0-1MW + Interconnection Driven by Record Exports

2Q25 Results

139

New Logos Added

\$90Mm

Record 2Q Bookings from
0-1MW + IX

66%

of total 2Q bookings from
0-1 MW + IX

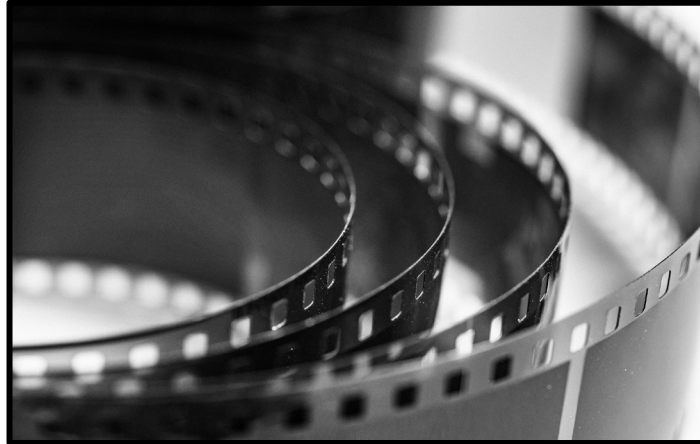

Robust Pricing Environment

Healthy Renewal Spreads

- *Renewal Spreads Increased Q/Q*
- *Guidance for Cash Renewal Spreads Increased*

2Q25 RENEWAL SPREADS

0-1 MW	> 1 MW	OTHER ⁽¹⁾	TOTAL
RENTAL RATE CHANGE	RENTAL RATE CHANGE	RENTAL RATE CHANGE	RENTAL RATE CHANGE
4.2% CASH / 5.0% GAAP	14.0% CASH / 20.5% GAAP	40.9% CASH / 73.0% GAAP	7.3% CASH / 9.9% GAAP
73% of total renewals	23% of total renewals	4% of total renewals	Signed renewals representing \$177 million of annualized rental revenue

Note: Totals may not add up due to rounding. Rental rate change represents the beginning rental rate on agreements renewed, relative to the ending rental rate at expiration, weighted by net rentable square feet. Signed renewals amounts represent cash annualized rental revenue.

1) Other includes Powered Base Building® shell capacity as well as storage and office space within fully improved data center facilities.

Lease Expirations Provide Re-Pricing Opportunities

- *Shorter term 0-1 MW leases provide near term opportunities to drive price increases*
- *Evenly staggered, longer term >1MW leases provide stability and visibility*

% of Lease Expirations by Annualized Base Rent ⁽¹⁾

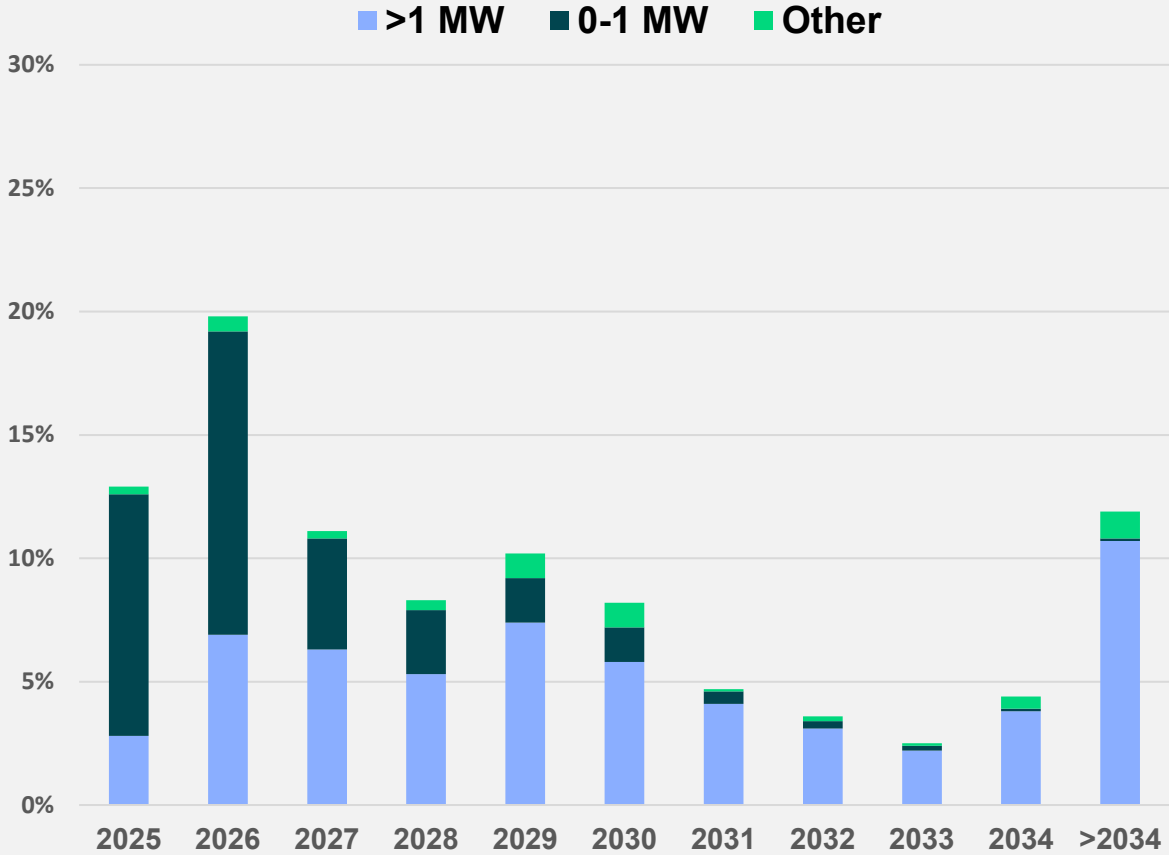

5% – 6%

2025 Guidance⁽²⁾ for cash rental rate on renewals

5.1 years

Weighted avg. remaining lease term

Note: As of June 30, 2025.
 1) Represents consolidated portfolio plus our managed portfolio of unconsolidated joint ventures based on our ownership percentage. Annualized base rent represents the monthly contractual base rent (defined as cash base rent before abatements) under existing leases as of June 30, 2025, multiplied by 12.
 2) Guidance as of July 24, 2025 only and has not been updated.

Multi-Year Backlog

Enhances Visibility

- Record Commencements of \$228Mm in 2Q25
- 29% of Backlog Expected to Commence in 2H25

BACKLOG ROLL-FORWARD (1)
\$ in millions

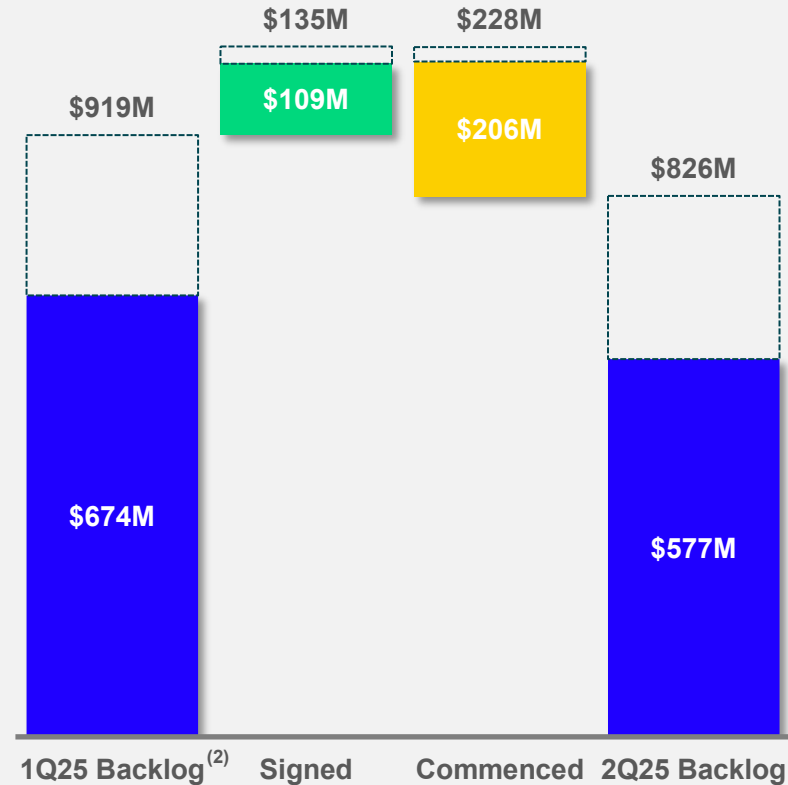

COMMENCEMENT TIMING (3)
\$ in millions

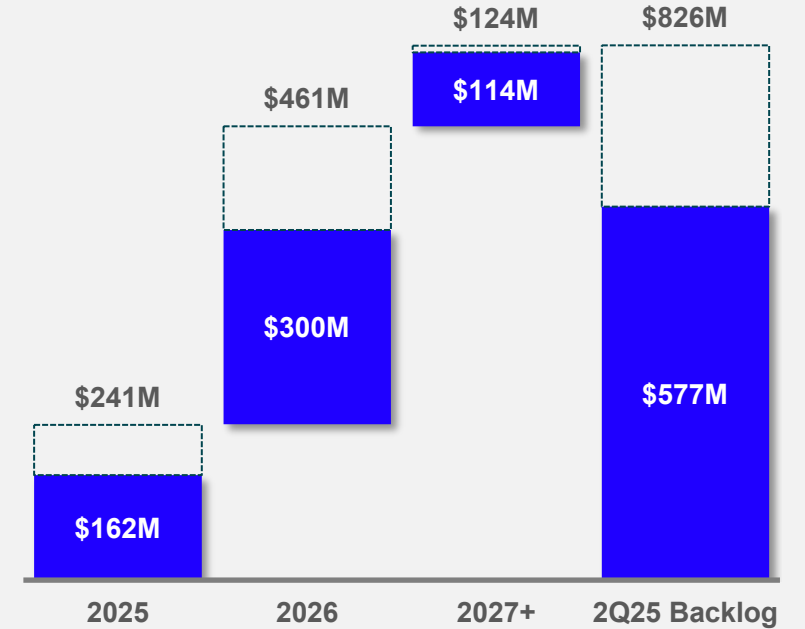

■ Digital Realty Backlog, at Share

□ Unconsolidated Entities Backlog, at DLR Share

Note: Totals may not add up due to rounding.

1) Amounts shown represent GAAP annualized base rent from leases signed.

2) Historical backlog adjusted for asset sales and purchases, joint venture and fund contributions and other non-material reconciling items.

3) Amounts shown represent GAAP annualized base rent from leases signed, but not yet commenced, based on estimated future commencement date at time of signing. Actual commencement dates may vary.

High-Quality, Diversified Customer Base

- *Top customers have a presence in 42 different locations, on average*

Customer Type (% by ARR) ⁽¹⁾

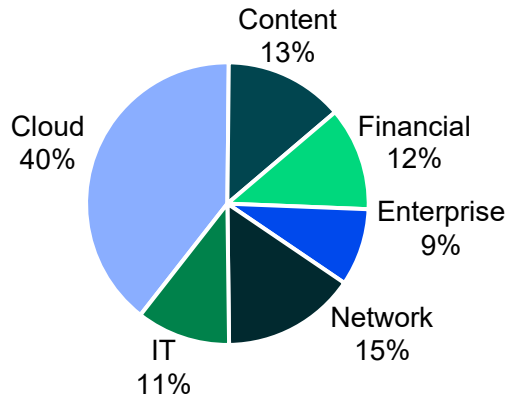

High-Quality Customer Base ⁽²⁾

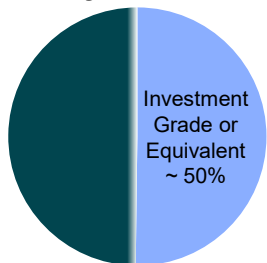

5,000+ Global Customers

TOP 20 CUSTOMERS

Customer Rank	Locations	% of ARR ⁽¹⁾	Customer Rank	Locations	% of ARR ⁽¹⁾		
1.	Fortune 50 Software Company	76	11.7%	11.	Specialized Cloud Provider	3	1.3%
2.		43	8.2%	12.		113	1.1%
3.	Social Content Platform	30	5.3%	13.	Fortune 25 Tech Company	55	1.1%
4.	Global Cloud Provider	64	4.6%	14.		77	1.0%
5.		36	2.7%	15.		45	1.0%
6.		16	2.1%	16.	JPMORGAN CHASE & Co.	20	0.9%
7.		7	2.0%	17.	Quantitative Research and Investment Firm	2	0.9%
8.		49	1.6%	18.		25	0.9%
9.	Fortune 25 Investment Grade-Rated Company	30	1.5%	19.	Morgan Stanley	13	0.9%
10.	Social Media Platform	4	1.4%	20.		117	0.8%
TOTAL ANNUALIZED RECURRING REVENUE					50.8%		

Note: As of June 30, 2025. Represents consolidated portfolio plus our managed portfolio of unconsolidated joint ventures based on our ownership percentage. Our direct customers may be the entities named in this table above or their subsidiaries or affiliates.

1) Calculation based on annualized recurring revenue – the monthly contractual base rent (defined as cash base rent before abatements), and Interconnection revenue under existing leases as of June 30, 2025, multiplied by 12.

2) Based on the credit ratings of Digital Realty's top 10 customers as of June 30, 2025 against annualized recurring total revenue of \$4.6 billion. Credit ratings from S&P, Moody's and Fitch reflect credit ratings of customer's parent entity. There can be no assurance that a customer's parent entity will satisfy the customer's lease or other obligations upon such customer's default.



Bolstered, Diversified...and Evolved

First U.S. Hyperscale Data Center Fund

>\$3Bn

LP Equity Commitments
To Date

>\$900Mm

Of Gross Proceeds
Realized in 2Q

The Fund is oversubscribed and expected to close ahead of schedule, supported by leading global investors.

- ✓ Exceeded target for LP equity commitments
- ✓ Contributed a 40% share of the **five** existing operating assets and an 80% share of **two** development sites
- ✓ Fund has the potential to support **>\$10 billion** of total data center investment from the existing commitments
- ✓ Digital Realty will maintain a $\geq 20\%$ GP interest in the Fund

Better Growth + Balance Sheet

Robust Liquidity, Below Target Leverage

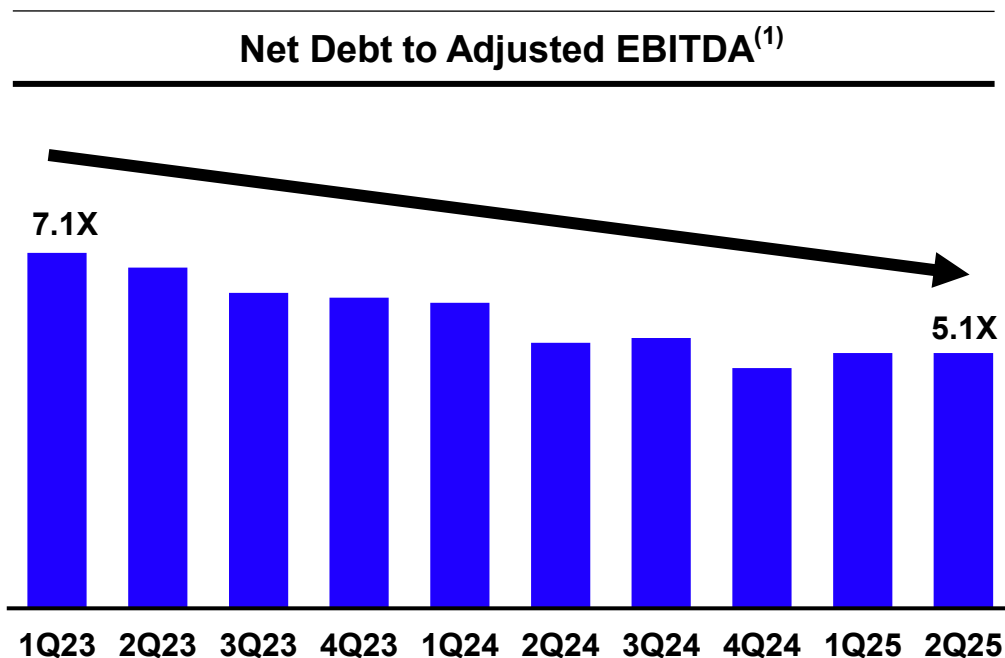

Credit Metric	Target	1Q23A	2Q25A
Net Debt to Adj. EBITDA ⁽¹⁾	5.5x Average	7.1x	5.1x
Fixed Charge Coverage	> 3.0x	4.4x	4.7x

Note: Please see Appendix for calculation of ratios.

1) Adjusted EBITDA is a non-GAAP financial measure. For reconciliation of these measures to their nearest GAAP equivalents, see the Appendix. As of June 30, 2025.

2) As of June 30, 2025. Totals includes investments in unconsolidated joint ventures.

3) Includes Digital Realty's pro rata share of unconsolidated joint venture loans and debt securities. Assumes exercise of extension options.

Capital Structure⁽²⁾

Equity Market Capitalization

\$60 Bn

Liquidity at the end of 2Q25

>\$7 Bn

Floating Rate Debt

7%

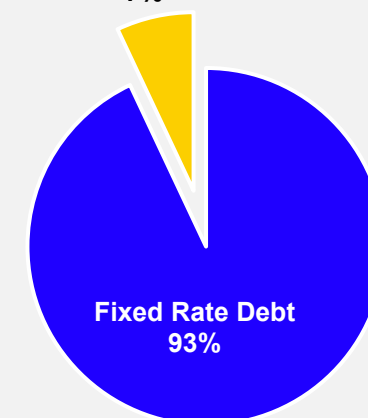

Fixed Rate Debt
93%

Debt Maturity Schedule⁽³⁾

(\$ in billions)

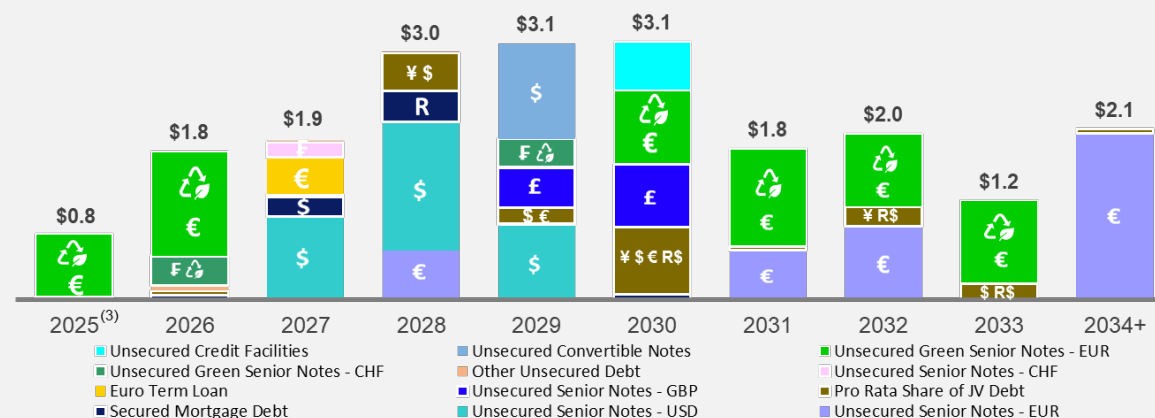

- Unsecured Credit Facilities
- Unsecured Green Senior Notes - CHF
- Euro Term Loan
- Secured Mortgage Debt
- Unsecured Convertible Notes
- Other Unsecured Debt
- Unsecured Senior Notes - GBP
- Unsecured Senior Notes - USD
- Unsecured Green Senior Notes - EUR
- Unsecured Senior Notes - CHF
- Pro Rata Share of JV Debt
- Unsecured Senior Notes - EUR

2025 Financial Guidance Update

Improving Core Growth

	As of Feb. 13, 2025	As of April 24, 2025	As of July 24, 2025	Better/Worse
Total Revenue	\$5,800 – \$5,900	\$5,825 - \$5,925	\$5,925 - \$6,025	▲
Adjusted EBITDA⁽¹⁾	\$3,100 – \$3,200	\$3,125 - \$3,225	\$3,200 - \$3,300	▲
Rental Rates on Renewal Leases (Cash)	4.0% – 6.0%	4.0% - 6.0%	5.0% - 6.0%	▲
Year-End Portfolio Occupancy	+100 – 200 bps	+100 – 200 bps	+100 – 200 bps	◀▶
Same-Capital Cash NOI Growth^{(1) (2)}	3.5% – 4.5%	3.5% – 4.5%	3.5% – 4.5%	◀▶
Core FFO per Share⁽¹⁾	\$7.00 – \$7.10	\$7.05 – 7.15	\$7.15 – 7.25	▲
Constant Currency Core FFO per Share⁽¹⁾	\$7.05 – \$7.15	\$7.05 – 7.15	\$7.10 – 7.20	▲

Note: Dollars in millions except Core FFO per Share. The Company does not provide a reconciliation for non-GAAP estimates on a forward-looking basis, as it is unable to provide a meaningful or accurate calculation or estimation of reconciling items and the information is not available without unreasonable effort. This is due to the inherent difficulty of forecasting the timing and/or amount of various items that would impact net income attributable to common stockholders per diluted share, which is the most directly comparable forward-looking GAAP financial measure. This includes, for example, external growth factors, such as dispositions, and balance sheet items, such as debt issuances, that have not yet occurred, are out of the Company's control and/or cannot be reasonably predicted. For the same reasons, the Company is unable to address the probable significance of the unavailable information. Forward-looking non-GAAP financial measures provided without the most directly comparable GAAP financial measures may vary materially from the corresponding GAAP financial measures.

- 1) Adjusted EBITDA, Same-Capital Cash NOI Growth, Core FFO Per Share, and Constant-Currency Core FFO per Share are non-GAAP financial measures. For definitions and reconciliation of these measures to their nearest GAAP equivalents, see the Appendix.
 2) Presented on a constant currency basis.



Appendix



Appendix

Management Statements on Non-GAAP Measures

The information included in this presentation contains certain non-GAAP financial measures that management believes are helpful in understanding our business, as further described below. Our definition and calculation of non-GAAP financial measures may differ from those of other REITs, and, therefore, may not be comparable. The non-GAAP financial measures should not be considered alternatives to net income or any other GAAP measurement of performance and should not be considered an alternative to cash flows from operating, investing or financing activities as a measure of liquidity.

Funds From Operations (FFO):

We calculate funds from operations, or FFO, in accordance with the standards established by the National Association of Real Estate Investment Trusts, or Nareit, in the Nareit Funds From Operations White Paper - 2018 Restatement. FFO represents net income (loss) (computed in accordance with GAAP), excluding gain (loss) from the disposition of real estate assets, provision for impairment, real estate related depreciation and amortization (excluding amortization of deferred financing costs), our share of unconsolidated JV real estate related depreciation & amortization, net income (loss) attributable to noncontrolling interests in operating partnership, and reconciling items related to noncontrolling interests. Management uses FFO as a supplemental performance measure because, in excluding real estate related depreciation and amortization and gains and losses from property dispositions and after adjustments for unconsolidated partnerships and entities, it provides a performance measure that, when compared year over year, captures trends in occupancy rates, rental rates and operating costs. We also believe that, as a widely recognized measure of the performance of REITs, FFO will be used by investors as a basis to compare our operating performance with that of other REITs. However, because FFO excludes depreciation and amortization and captures neither the changes in the value of our data centers that result from use or market conditions, nor the level of capital expenditures and capitalized leasing commissions necessary to maintain the operating performance of our data centers, all of which have real economic effect and could materially impact our financial condition and results from operations, the utility of FFO as a measure of our performance is limited. Other REITs may not calculate FFO in accordance with the Nareit definition and, accordingly, our FFO may not be comparable to other REITs' FFO. FFO should be considered only as a supplement to net income computed in accordance with GAAP as a measure of our performance.

Core Funds from Operations (Core FFO):

We present core funds from operations, or Core FFO, as a supplemental operating measure because, in excluding certain items that do not reflect core revenue or expense streams, it provides a performance measure that, when compared year over year, captures trends in our core business operating performance. We calculate Core FFO by adding to or subtracting from FFO (i) other non-core revenue adjustments, (ii) transaction and integration expenses, (iii) loss on debt extinguishment and modifications, (iv) gain on / issuance costs associated with redeemed preferred stock, (v) severance, equity acceleration, and legal expenses, (vi) gain/loss on FX and derivatives revaluation, and (vii) other non-core expense adjustments. Because certain of these adjustments have a real economic impact on our financial condition and results from operations, the utility of Core FFO as a measure of our performance is limited. Other REITs may calculate Core FFO differently than we do and accordingly, our Core FFO may not be comparable to other REITs' Core FFO. Core FFO should be considered only as a supplement to net income computed in accordance with GAAP as a measure of our performance.

EBITDA and Adjusted EBITDA:

We believe that earnings before interest, loss on debt extinguishment and modifications, income taxes, and depreciation and amortization, or EBITDA, and Adjusted EBITDA (as defined below), are useful supplemental performance measures because they allow investors to view our performance without the impact of non-cash depreciation and amortization or the cost of debt and, with respect to Adjusted EBITDA, (i) unconsolidated entities real estate related depreciation & amortization, (ii) unconsolidated entities interest expense and tax expense, (iii) severance, equity acceleration, and legal expenses, (iv) transaction and integration expenses, (v) gain (loss) on sale / deconsolidation, (vi) provision for impairment, (vii) other non-core adjustments, net, (viii) non-controlling interests, (ix) preferred stock dividends, and (x) issuance costs associated with redeemed preferred stock. Adjusted EBITDA is EBITDA excluding unconsolidated entities real estate related depreciation & amortization, unconsolidated entities interest expense and tax, severance, equity acceleration, and legal expenses, transaction and integration expenses, gain (loss) on sale / deconsolidation, provision for impairment, other non-core adjustments, net, non-controlling interests, preferred stock dividends, and gain on / issuance costs associated with redeemed preferred stock. In addition, we believe EBITDA and Adjusted EBITDA are frequently used by securities analysts, investors and other interested parties in the evaluation of REITs. Because EBITDA and Adjusted EBITDA are calculated before recurring cash charges including interest expense and income taxes, exclude capitalized costs, such as leasing commissions, and are not adjusted for capital expenditures or other recurring cash requirements of our business, their utility as a measure of our performance is limited. Other REITs may calculate EBITDA and Adjusted EBITDA differently than we do and, accordingly, our EBITDA and Adjusted EBITDA may not be comparable to other REITs' EBITDA and Adjusted EBITDA. Accordingly, EBITDA and Adjusted EBITDA should be considered only as supplements to net income computed in accordance with GAAP as a measure of our financial performance.

Net Operating Income (NOI) and Cash NOI:

Net operating income, or NOI, represents rental revenue, tenant reimbursement revenue and interconnection revenue less utilities expense, rental property operating expenses, property taxes and insurance expenses (as reflected in the statement of operations). NOI is commonly used by stockholders, company management and industry analysts as a measurement of operating performance of the company's rental portfolio. Cash NOI is NOI less straight-line rents and above- and below-market rent amortization. Cash NOI is commonly used by stockholders, company management and industry analysts as a measure of property operating performance on a cash basis. However, because NOI and cash NOI exclude depreciation and amortization and capture neither the changes in the value of our data centers that result from use or market conditions, nor the level of capital expenditures and capitalized leasing commissions necessary to maintain the operating performance of our data centers, all of which have real economic effect and could materially impact our results from operations, the utility of NOI and cash NOI as measures of our performance is limited. Other REITs may calculate NOI and cash NOI differently than we do and, accordingly, our NOI and cash NOI may not be comparable to other REITs' NOI and cash NOI. NOI and cash NOI should be considered only as supplements to net income computed in accordance with GAAP as measures of our performance.

Same-Capital Cash NOI:

Same-Capital Cash NOI represents buildings owned as of December 31, 2023 with less than 5% of total rentable square feet under development and excludes buildings that were undergoing, or were expected to undergo, development activities in 2024-2025, buildings classified as held for sale, and buildings sold or contributed to entities for all periods presented (prior period numbers are adjusted to reflect the current same-capital pool).

Appendix

Forward-Looking Statements

This information in this presentation contains forward-looking statements within the meaning of the federal securities laws, which are based on current expectations, forecasts and assumptions that involve risks and uncertainties that could cause actual outcomes and results to differ materially. Such forward-looking statements include statements relating to: our economic outlook; our expected investment and expansion activity; our joint ventures; the expected benefits and timing of PlatformDIGITAL®; the Data Gravity Index™; Data Gravity Index DGx™; public cloud services spending; the potential impact of artificial intelligence and data regulations; our sustainability initiatives; the expected effect of foreign currency translation adjustments on our financials; anticipated continued demand for our products and services; our liquidity; demand drivers and economic growth outlook; business drivers; our expected development plans and completions, including timing, total square footage, IT capacity and raised floor space upon completion; expected availability for leasing efforts and colocation initiatives; organizational initiatives; our product offerings; our connected data communities; joint venture opportunities; occupancy and total investment; our expected investment in our properties; our estimated time to stabilization and targeted returns at stabilization of our properties; our expected future acquisitions; acquisitions strategy; available inventory and development strategy; the signing and commencement of leases, and related rental revenue; lag between signing and commencement of leases; our 2025 backlog; future rents; our expected same store portfolio growth; our expected growth and stabilization of development completions and acquisitions; lease rollovers and expected rental rate changes; our re-leasing spreads; our expected yields on investments; our expectations with respect to capital investments at lease expiration on existing data center or colocation space; debt maturities; lease maturities; our other expected future financial and other results including guidance, and the assumptions underlying such results; our customers' capital investments; our plans and intentions; future data center utilization, utilization rates, growth rates, trends, supply and demand; data center expansion plans; estimated kW/MW requirements; capital expenditures; the effect new leases and increases in rental rates will have on our rental revenues and results of operations; estimates of the value of our development portfolio; our ability to meet our liquidity needs, including the ability to raise additional capital; access to power; market forecasts; projected financial information and covenant metrics; Core FFO run rate and NOI growth; other forward looking financial data; leasing expectations; our exposure to tenants in certain industries; our expectations and underlying assumptions regarding our sensitivity to fluctuations in foreign exchange rates; and the sufficiency of our capital to fund future requirements. You can identify forward-looking statements by the use of forward-looking terminology such as "believes," "expects," "may," "will," "should," "seeks," "approximately," "intends," "plans," "pro forma," "estimates" or "anticipates" or the negative of these words and phrases or similar words or phrases which are predictions of or indicate future events or trends and discussions which do not relate solely to historical matters. Such statements are based on management's beliefs and assumptions made based on information currently available to management. Such statements are subject to risks, uncertainties and assumptions and are not guarantees of future performance and may be affected by known and unknown risks, trends, uncertainties and factors that are beyond our control. Should one or more of these risks or uncertainties materialize, or should underlying assumptions prove incorrect, actual results may vary materially from those anticipated, estimated or projected. Some of the risks and uncertainties that may cause our actual results, performance or achievements to differ materially from those by forward-looking statements include, among others, the following: reduced demand for data centers or decreases in information technology spending; decreased rental rates, increased operating costs or increased vacancy rates; increased competition or available supply of data center space; the suitability of our data centers and data center infrastructure, delays or disruptions in connectivity or availability of power, or failures or breaches of our physical and information security infrastructure or services; breaches of our obligations or restrictions under our contracts with our customers; our inability to successfully develop and lease new properties and development space, and delays or unexpected costs in development of properties; the impact of current global and local economic, credit and market conditions; increased tariffs, global supply chain or procurement disruptions, or increased supply chain costs; the impact from periods of heightened inflation on our costs, such as operating and general and administrative expenses, interest expense and real estate acquisition and construction costs; the impact on our customers' and our suppliers' operations during an epidemic, pandemic, or other global events; our dependence upon significant customers, bankruptcy or insolvency of a major customer or a significant number of smaller customers, or defaults on or non-renewal of leases by customers; changes in political conditions, geopolitical turmoil, political instability, civil disturbances, restrictive governmental actions or nationalization in the countries in which we operate; our inability to retain data center space that we lease or sublease from third parties; information security and data privacy breaches; difficulties managing an international business and acquiring or operating properties in foreign jurisdictions and unfamiliar metropolitan areas; our failure to realize the intended benefits from, or disruptions to our plans and operations or unknown or contingent liabilities related to, our recent and future acquisitions; our failure to successfully integrate and operate acquired or developed properties or businesses; difficulties in identifying properties to acquire and completing acquisitions; risks related to joint venture investments, including as a result of our lack of control of such investments; risks associated with using debt to fund our business activities, including re-financing and interest rate risks, our failure to repay debt when due, adverse changes in our credit ratings or our breach of covenants or other terms contained in our loan facilities and agreements; our failure to obtain necessary debt and equity financing, and our dependence on external sources of capital; financial market fluctuations and changes in foreign currency exchange rates; adverse economic or real estate developments in our industry or the industry sectors that we sell to, including risks relating to decreasing real estate valuations and impairment charges and goodwill and other intangible asset impairment charges; our inability to manage our growth effectively; losses in excess of our insurance coverage; our inability to attract and retain talent; environmental liabilities, risks related to natural disasters and our inability to achieve our sustainability goals; the expected operating performance of anticipated near-term acquisitions and descriptions relating to these expectations; our inability to comply with rules and regulations applicable to our company; Digital Realty Trust, Inc.'s failure to maintain its status as a REIT for U.S. federal income tax purposes; Digital Realty Trust, L.P.'s failure to qualify as a partnership for U.S. federal income tax purposes; restrictions on our ability to engage in certain business activities; and changes in local, state, federal and international laws and regulations, including related to taxation, real estate and zoning laws and increases in real property tax rates; the impact of any financial, accounting, legal or regulatory issues or litigation that may affect us.

The risks included here are not exhaustive, and additional factors could adversely affect our business and financial performance. We discussed a number of additional material risks in our annual report on Form 10-K for the year ended December 31, 2024, and other filings with the Securities and Exchange Commission. Those risks continue to be relevant to our performance and financial condition. Moreover, we operate in a very competitive and rapidly changing environment. New risk factors emerge from time to time and it is not possible for management to predict all such risk factors, nor can it assess the impact of all such risk factors on the business or the extent to which any factor, or combination of factors, may cause actual results to differ materially from those contained in any forward-looking statements. We expressly disclaim any responsibility to update forward-looking statements, whether as a result of new information, future events or otherwise. Digital Realty, Digital Realty Trust, the Digital Realty logo, Interxion, Turn-Key Flex, Powered Base Building, PlatformDIGITAL, Data Gravity Index, Data Gravity Index DGx, ServiceFabric, AnyScale Colo, and Pervasive Data Center Architecture (PDx), among others, are registered trademarks and service marks of Digital Realty Trust, Inc. in the United States and/or other countries. All other names, trademarks and service marks are the property of their respective owners.

Reconciliation of Non-GAAP Items To Their Closest GAAP Equivalent

Digital Realty Trust, Inc. and Subsidiaries
Reconciliation of Funds From Operations (FFO) to Core Funds From Operations (CFFO)
(in thousands, except per share and unit data)
(unaudited)

	Three Months Ended	
	June 30, 2025	June 30, 2024
FFO available to common stockholders and unitholders -- diluted	\$ 600,329	\$ 510,852
Other non-core revenue adjustments	4,228	(33,818)
Transaction and integration expenses	22,546	26,072
Loss from early extinguishment of debt	-	-
Severance, equity acceleration and legal expenses	2,262	884
(Gain) / Loss on FX and derivatives revaluation	8,827	32,222
Other non-core expense adjustments	5,092	2,271
CFFO available to common stockholders and unitholders -- diluted	\$ 643,284	\$ 538,482
CFFO impact of holding '24 Exchange Rates Constant	(11,688)	-
Constant Currency CFFO available to common stockholders and unitholders -- diluted	\$ 631,596	\$ 538,482
Diluted CFFO per share and unit	\$ 1.87	\$ 1.65
Diluted Constant Currency CFFO per share and unit	\$ 1.84	\$ 1.65

Reconciliation of Non-GAAP Items To Their Closest GAAP Equivalent

Digital Realty Trust, Inc. and Subsidiaries

Reconciliation of Net Income Available to Common Stockholders to Earnings Before Interest, Taxes, Depreciation and Amortization (EBITDA) and Adjusted EBITDA

(in thousands)

(unaudited)

	Three Months Ended	
	June 30, 2025	June 30, 2024
Net income available to common stockholders	\$ 1,021,975	\$ 70,039
Interest	109,383	114,756
Loss from early extinguishment of debt	-	-
Income tax expense (benefit)	12,883	14,992
Depreciation and amortization	461,167	425,343
EBITDA	1,605,408	625,130
Unconsolidated JV real estate related depreciation & amortization	59,172	47,117
Unconsolidated JV interest expense and tax expense	31,243	27,704
Severance, equity acceleration and legal expenses	2,262	884
Transaction and integration expenses	22,546	26,072
(Gain) / loss on sale of investments	(931,830)	(173,709)
Provision for impairment	-	168,303
Other non-core adjustments, net	9,545	743
Noncontrolling interests	14,790	(5,552)
Preferred stock dividends, including undeclared dividends	10,181	10,181
(Gain) on redemption of preferred stock	-	-
Adjusted EBITDA	\$ 823,319	\$ 726,874

Reconciliation of Non-GAAP Items To Their Closest GAAP Equivalent

Total Debt/Total Enterprise Value		
Market value of common equity ⁽ⁱ⁾	\$	29,272,861
Liquidation value of preferred equity ⁽ⁱⁱ⁾		755,000
Total debt at balance sheet carrying value		17,875,511
Total Enterprise Value	\$	47,903,372
Total debt / total enterprise value		37.3%
Debt-plus-preferred-to-total-enterprise-value		38.9%
(i) Market Value of Common Equity		
Common shares outstanding		291,299
Common units outstanding		6,462
Total Shares and Partnership Units		297,761
Stock price as of March 31, 2023	\$	98.31
Market value of common equity	\$	29,272,861
(ii) Liquidation value of preferred equity (\$25.00 per share)		
	Shares O/S	Liquidation Value
Series J Preferred	8,000	200,000
Series K Preferred	8,400	210,000
Series L Preferred	13,800	345,000
		755,000 ^(iv)

Net Debt/LQA Adjusted EBITDA		
		QE 03/31/23
Total debt at balance sheet carrying value	\$	17,875,511
Add: DLR share of unconsolidated joint venture debt		1,123,360
Add: Capital lease obligations, net		335,910
Less: Unrestricted cash		(361,380)
Net Debt as of March 31, 2023	\$	18,973,401
Net Debt / LQA Adjusted EBITDA ⁽ⁱⁱⁱ⁾		7.1x
(iii) Adjusted EBITDA		
Net loss available to common stockholders	\$	58,547
Interest expense		102,220
Taxes		21,454
Depreciation and amortization		421,198
EBITDA		603,419
Unconsolidated JV real estate related depreciation & amortization		33,719
Unconsolidated JV interest expense and tax expense		18,556
Severance accrual and equity acceleration and legal expenses		4,155
Transaction and integration expenses		12,267
Other non-core adjustments, net		(14,604)
Noncontrolling interests		111
Preferred stock dividends, including undeclared dividends		10,181
Adjusted EBITDA	\$	667,804
LQA Adjusted EBITDA (Adjusted EBITDA x 4)	\$	2,671,214

Debt Service Ratio (LQA Adjusted EBITDA/GAAP interest expense plus capitalized interest and less bridge facility fees)		QE 03/31/23
Total GAAP interest expense (including unconsolidated JV interest expense)		113,931
Add: Capitalized interest		26,771
GAAP interest expense plus capitalized interest		140,702
Debt Service Ratio		4.7x

Fixed Charged Ratio (LQA Adjusted EBITDA/total fixed charges)		QE 03/31/23
GAAP interest expense plus capitalized interest		140,702
Preferred dividends		10,181
Total fixed charges		150,884
Fixed charge ratio		4.4x

Unsecured Debt/Total Debt		QE 03/31/23
Global unsecured revolving credit facility		2,514,202
Unsecured term loans		1,542,275
Unsecured senior notes, net of discount		13,258,079
Secured debt, including premiums		560,955
Capital lease obligations, net		335,910
Total debt at balance sheet carrying value		18,211,421
Unsecured Debt / Total Debt		96.9%

Net Debt Plus Preferred/LQA Adjusted EBITDA		QE 03/31/23
Total debt at balance sheet carrying value		17,875,511
Less: Unrestricted cash		(361,380)
Capital lease obligations, net		335,910
DLR share of unconsolidated joint venture debt		1,123,360
Net Debt as of March 31, 2023		18,973,401
Preferred Liquidation Value ^(iv)		755,000
Net Debt plus preferred		19,728,401
Net Debt Plus Preferred/LQA Adjusted EBITDA ⁽ⁱⁱⁱ⁾		7.4x

Reconciliation of Non-GAAP Items To Their Closest GAAP Equivalent

Total Debt/Total Enterprise Value		
Market value of common equity ⁽ⁱ⁾	\$	60,430,449
Liquidation value of preferred equity ⁽ⁱⁱ⁾		755,000
Total debt at balance sheet carrying value		18,452,148
Total Enterprise Value	\$	79,637,597
Total debt / total enterprise value		23.2%
Debt-plus-preferred-to-total-enterprise-value		24.1%
(i) Market Value of Common Equity		
Common shares outstanding		340,372
Common units outstanding		6,272
Total Shares and Partnership Units		346,644
Stock price as of June 30, 2025	\$	174.33
Market value of common equity	\$	60,430,449
(ii) Liquidation value of preferred equity (\$25.00 per share)		
	Shares O/S	Liquidation Value
Series J Preferred	8,000	200,000
Series K Preferred	8,400	210,000
Series L Preferred	13,800	345,000
		755,000 ^(iv)

Net Debt/LQA Adjusted EBITDA		QE 06/30/25
Total debt at balance sheet carrying value	\$	18,452,148
Add: DLR share of unconsolidated joint venture debt		2,044,648
Add: Capital lease obligations, net		351,167
Less: Unrestricted cash		(3,982,212)
Net Debt as of June 30, 2025	\$	16,865,751
Net Debt / LQA Adjusted EBITDA ⁽ⁱⁱⁱ⁾		5.1x
(iii) Adjusted EBITDA		
Net loss available to common stockholders	\$	1,021,975
Interest expense		109,383
Loss from early extinguishment of debt		-
Taxes		12,883
Depreciation and amortization		461,167
EBITDA		1,605,408
Unconsolidated JV real estate related depreciation & amortization		59,172
Unconsolidated JV interest expense and tax expense		31,243
Severance accrual and equity acceleration and legal expenses		2,262
Transaction and integration expenses		22,546
(Gain) / loss on sale of investments		(931,830)
Provision for impairment		-
Other non-core adjustments, net		9,545
Noncontrolling interests		14,790
Preferred stock dividends		10,181
Adjusted EBITDA	\$	823,319
LQA Adjusted EBITDA (Adjusted EBITDA x 4)	\$	3,293,277

Debt Service Ratio (LQA Adjusted EBITDA/GAAP interest expense plus capitalized interest and less bridge facility fees)		QE 06/30/25
Total GAAP interest expense (including unconsolidated JV interest expense)		135,899
Add: Capitalized interest		29,393
GAAP interest expense plus capitalized interest		165,292
Debt Service Ratio		5.0x

Fixed Charged Ratio (LQA Adjusted EBITDA/total fixed charges)		QE 06/30/25
GAAP interest expense plus capitalized interest		165,292
Preferred dividends		10,181
Total fixed charges		175,473
Fixed charge ratio		4.7x

Unsecured Debt/Total Debt		QE 06/30/25
Global unsecured revolving credit facility		567,699
Unsecured term loans		440,788
Unsecured senior notes, net of discount		16,641,367
Secured debt, including premiums		802,294
Capital lease obligations, net		351,167
Total debt at balance sheet carrying value		18,803,315
Unsecured Debt / Total Debt		95.7%

Net Debt Plus Preferred/LQA Adjusted EBITDA		QE 06/30/25
Total debt at balance sheet carrying value		18,452,148
Less: Unrestricted cash		(3,982,212)
Capital lease obligations, net		351,167
DLR share of unconsolidated joint venture debt		2,044,648
Net Debt as of June 30, 2025		16,865,751
Preferred Liquidation Value ^(iv)		755,000
Net Debt plus preferred		17,620,751
Net Debt Plus Preferred/LQA Adjusted EBITDA ⁽ⁱⁱⁱ⁾		5.4x

Note: For quarter ended June 30, 2025



Thank you

